

A

PLAN VIEW
(N.T.S.)

NOTE : BUILDING
HEIGHT WITHOUT
EXTERIOR ROOF- 86 9/16"

DOORS AVAILABLE BOTH SIDES-SUFFIX DSL
CASHIER WINDOW AVAILABLE
IN SLIDING DOOR-SUFFIX CSL

STANDARD ITEMS FOR A S9648SL DURALUMINUM BUILDING

- ① — 100 AMP SINGLE PHASE 12 CIRCUIT MAIN LOAD CENTER
- ② — 115V DUPLEX, 230V OUTLET
- ③ — 40 WATT LIGHT FIXTURE
- ④ — 22" DEEP SHELF
- ⑤ — 3" OVERHANG EXTERIOR ROOF (OPTIONAL)
- * 1/4" ACRYLIC WRAP-AROUND GLAZING
(REFER TO DURALUMINUM SPECIFICATIONS
FOR TYPICAL CONSTRUCTION)

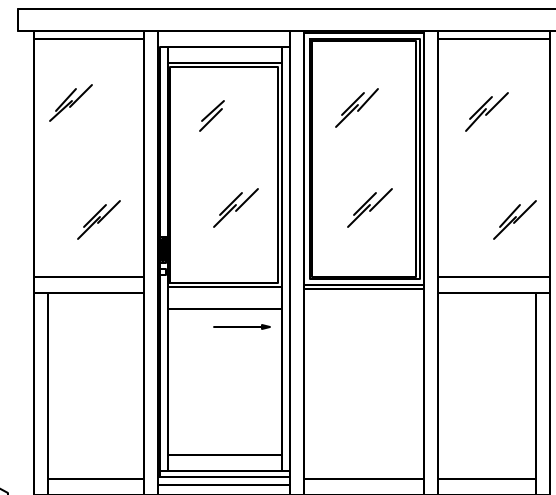

ELEVATION A

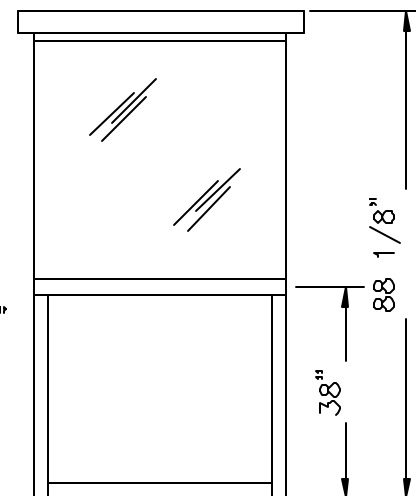

ELEVATION B

PORTA-KING BUILDING SYSTEMS

4133 SHORELINE DRIVE EARTH CITY, MISSOURI 63045
1-800-456-5464 FAX 314-291-2857 www.portaking.com

TITLE

DURALUMINUM MODEL S9648SL